

NCS-C251 Expansion Unit INSTRUCTION MANUAL

Rev 0



New Communications Solutions, LLC
5364 Valley Mist Trace
Suite 101
Norcross, Georgia 30092

Toll Free Tel. & Fax : 888- 883-5788
Email : support@ncsradio.com
Web Site: www.ncsradio.com



| Revision History | | | |
|-------------------------|--------------------|-------------|-----------------|
| Rev | Description | Date | Approved |
| | | | |
| | | | |
| | | | |
| | | | |
| | | | |
| | | | |
| | | | |
| | | | |
| | | | |
| | | | |

**FACTORY INSTALLED OPTION
IDENTIFICATION TABLE**

The Serial Number Label located on the bottom of the unit indicates which Options are installed according to the following chart:

| Option | COR | HookSwitch | Multicast | Sidetone |
|---------------|------------|-------------------|------------------|-----------------|
| M00 | | | | |
| M04 | X | | | |
| M05 | | X | | |
| M06 | X | X | | |
| M08 | | | X | |
| M09 | X | | X | |
| M10 | | X | X | |
| M11 | X | X | X | |
| M12 | | | | X |
| M13 | X | | | X |
| M14 | | X | | X |
| M15 | | | X | X |
| M16 | X | X | | X |
| M17 | X | | X | X |
| M18 | | X | X | X |
| M19 | X | X | X | X |

NOTE: The COR and Hookswitch Options require that an Option Board be installed in the C251 at the factory. The Multicast and Sidetone Options are set in the C251 by an attached C250.

Table of Contents

| | |
|--|----|
| 1.0 Introduction..... | 4 |
| 2.0 Safety Information | 5 |
| 3.0 Accessory Kit..... | 6 |
| 4.0 Front Panel Controls and Indicators..... | 6 |
| 5.0 Power Supply | 7 |
| 6.0 Microphone Setup | 8 |
| 7.0 Rear Panel Connections | 9 |
| 8.0 Connecting the C251 to the C250A..... | 11 |
| 9.0 Radio Interface Cables..... | 11 |
| 10.0 Adjustments..... | 13 |
| 11.0 Operating the C251 | 15 |
| 12.0 COR/Hookswitch Option Board..... | 16 |
| 13.0 Block Diagram | 19 |
| 14.0 Troubleshooting..... | 20 |
| 15.0 Contacting NCS..... | 21 |
| 16.0 C251 Specifications..... | 22 |

1.0 Introduction

The C251 adds four additional radio connections to the NCS C-250A. All functions are controlled by the NCS-C250A Main Unit except selection of Radios 5 through 8. These radios are selected on the front panel of the NCS-C251 Expansion Unit.

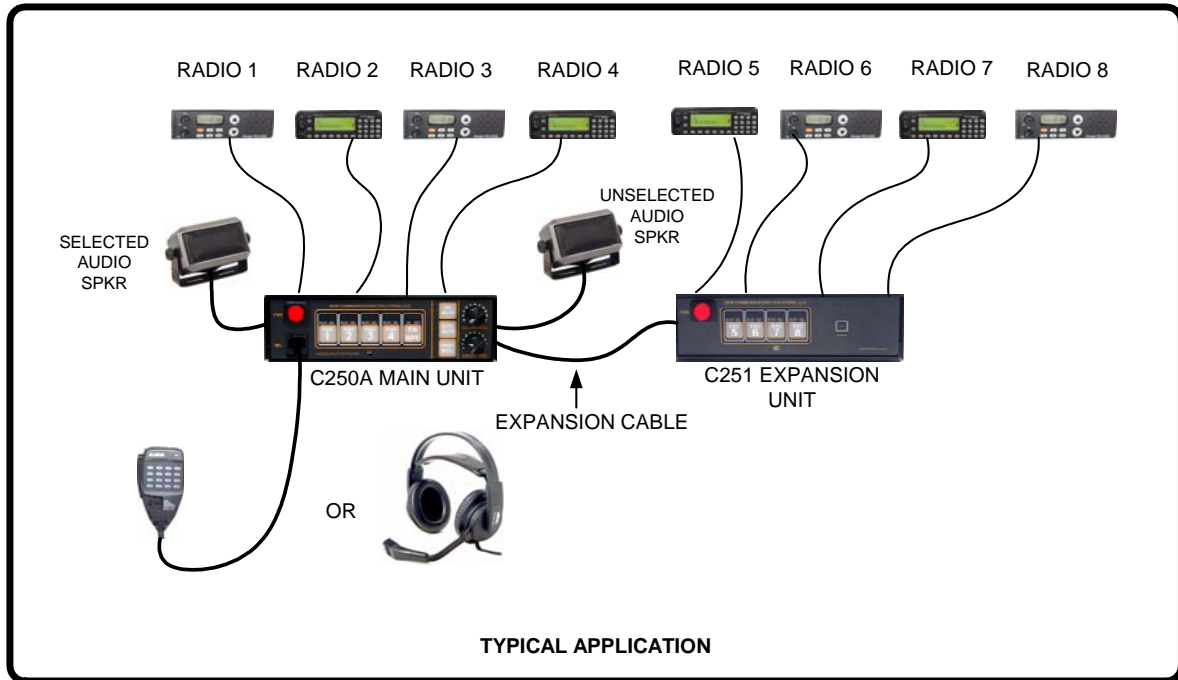

Typical Application

2.0 Safety Information

The C251 is an electrical device requiring appropriate safety measures during installation and operation. The following safety precautions should be observed:

- When connecting the unit to a DC power source, a minimum wire size of 18 AWG should be used. When using in a mobile environment, automotive grade wire should be used.
- Do not route cables or wires through areas that may cause the insulation to be worn resulting in shorting of the wires to ground or to each other.
- Always replace fuses with the ratings specified by the manufacturer.
- Do not place your ears in close proximity to the local speakers or PA speaker at high volume settings. Your hearing could be impaired as a result.
- Do not attempt to operate this equipment while driving a vehicle. For safety, pull over to the side of the road when making adjustments.
- **NEVER** connect this device to an AC voltage source. Death or injury could occur and/or the unit can be badly damaged. Connect this device only to a DC power source with a voltage output of 12-15 volts and a current capability of at least 2A.

3.0 Accessory Kit

An Accessory Kit is packed with the C251. The following items are included in the Kit:

| Item | Quantity | Description |
|------------------------|----------|---|
| Power Cable, DC | 1 | 10 foot cable for connecting C251 to DC power source. |
| Expansion Cable | 1 | Connects the C251 Expansion Unit to the Main C250. |
| Fuse, 5x20mm | 2 | Spare 3A fuses. |
| Mounting Feet | 4 | Used for table-top installation. |
| Clamp, Power Connector | 1 | Used to clamp the C251 power pigtail connector to the DC Power Cable. |

4.0 Front Panel Controls and Indicators

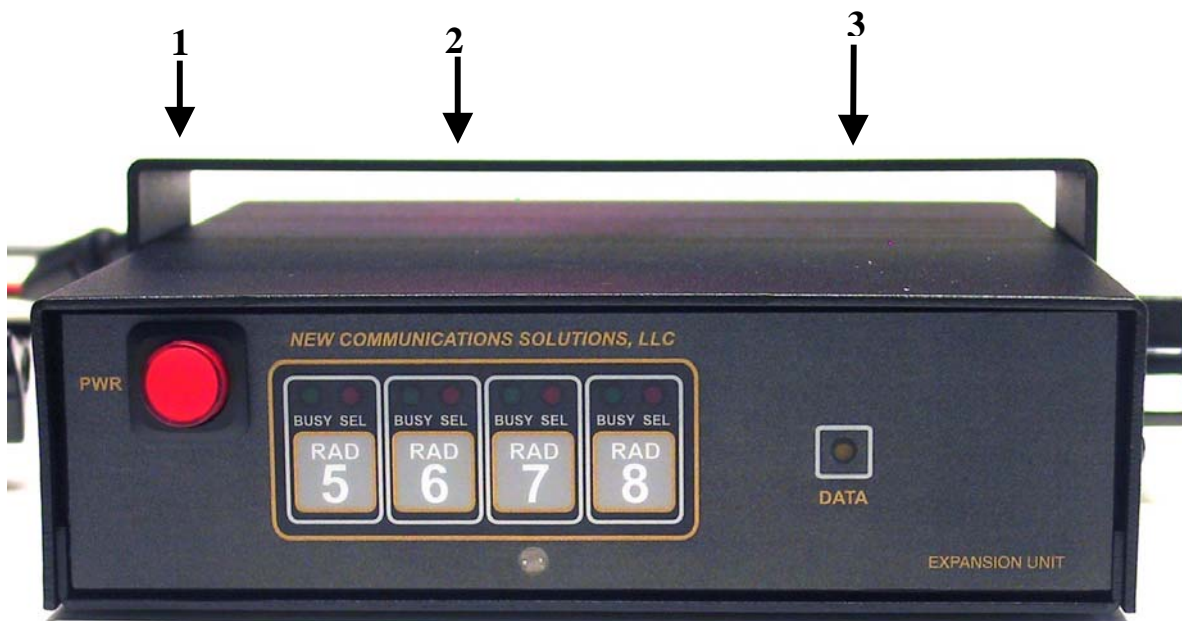

| Item | Description |
|------|---|
| 1 | Power Switch with Red LED Indicator- Latching |
| 2 | Radio Select Switches with Red Selected and Green Busy Indicators. |
| 3 | DATA light flashes during communication between Main C250 and the C251. |

5.0 Power Supply

5.1 Power Requirements

The NCS-C251 will operate with any 9-16 VDC power supply capable of providing at least 2A continuous.

5.2 Power Connection

Power is supplied to the pigtail on the rear of the unit. The connector is an Anderson Powerpole PP-15. As part of the accessory kit, a 10 foot power cable is supplied with a mating connector attached. Connect the power cable to a 9-16 VDC source capable of supplying at least 2A. Additional connectors are available from Powerwerx (web site: <http://www.powerwerx.com>, telephone: 714-570-3303)

5.3 Polarity

Power cable polarity is: Red = +, Black = - (or chassis).

5.4 Fusing

Both power supply lines are fused with fast-acting 3A 5x20 mm fuses (Wickmann USA series 191 or equivalent).

5.5 Using an AC Power Supply

The C251 can be operated from any well-regulated 9-16 VDC power supply capable of delivering a minimum of 2 Amperes. Voltages higher than 16V may result in damage to the circuitry.

5.6 Power Cable Clamp

The Power Cable Clamp is used to keep the Power Cable from separating from the Power Pigtail in Mobile use.

6.0 Microphone Setup

6.1 Internal Setup

Microphones are not connected directly to the NCS-C251 Expansion Unit so no setup is required.

6.2 Rear Panel Microphone Connections

Do not use the rear panel Microphone Connector on the NCS-C251 Expansion Unit.

7.0 Rear Panel Connections



RAD5 RAD6 RAD7 RAD8

These RAD Numbers correspond to the Front Panel Buttons on the C251 Expansion Unit.

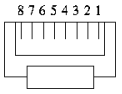
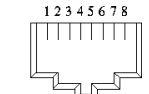
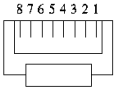
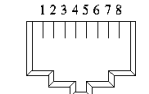
| NAME | PINOUT | NOTES | | | | | | | | | | | | | | | | | | | | | | | | | | | |
|---|--|--|--------|------|---|----------------|--------------------|---|-----------------------|----------------------------------|---|-----|--------------------|---|-----|---------------|---|---------------|-----------------------------------|---|-----|---------------|---|------------|--------------|---|-----|---------------|---|
| MIC RJ45 Connector on Rear Panel |   <p>Figure 1: End view of RJ45 Plug</p> <p>Figure 2: Looking into an RJ45 Jack</p> | DO NOT USE on the C251 Expansion Unit. | | | | | | | | | | | | | | | | | | | | | | | | | | | |
| RAD1-RAD4 (RAD5-RAD8) RJ45 Connectors on Rear Panel |   <p>Figure 1: End view of RJ45 Plug</p> <p>Figure 2: Looking into an RJ45 Jack</p> <table border="1" data-bbox="949 1003 1461 1334"> <thead> <tr> <th>Pin</th> <th>Signal</th> <th>Note</th> </tr> </thead> <tbody> <tr> <td>1</td> <td>Transmit Audio</td> <td>To Radio Mic Input</td> </tr> <tr> <td>2</td> <td>Transmit Audio Common</td> <td>To Radio Mic Input Common or Gnd</td> </tr> <tr> <td>3</td> <td>PTT</td> <td>To Radio PTT Input</td> </tr> <tr> <td>4</td> <td>GND</td> <td>Signal Ground</td> </tr> <tr> <td>5</td> <td>Receive Audio</td> <td>From Radio Audio (Speaker) Output</td> </tr> <tr> <td>6</td> <td>GND</td> <td>Signal Ground</td> </tr> <tr> <td>7</td> <td>Hookswitch</td> <td>Out to Radio</td> </tr> <tr> <td>8</td> <td>COR</td> <td>In from Radio</td> </tr> </tbody> </table> | Pin | Signal | Note | 1 | Transmit Audio | To Radio Mic Input | 2 | Transmit Audio Common | To Radio Mic Input Common or Gnd | 3 | PTT | To Radio PTT Input | 4 | GND | Signal Ground | 5 | Receive Audio | From Radio Audio (Speaker) Output | 6 | GND | Signal Ground | 7 | Hookswitch | Out to Radio | 8 | COR | In from Radio | These connections correspond to RAD5-RAD8 on the Front Panel. Hookswitch and COR require Factory Installed Option Board. |
| Pin | Signal | Note | | | | | | | | | | | | | | | | | | | | | | | | | | | |
| 1 | Transmit Audio | To Radio Mic Input | | | | | | | | | | | | | | | | | | | | | | | | | | | |
| 2 | Transmit Audio Common | To Radio Mic Input Common or Gnd | | | | | | | | | | | | | | | | | | | | | | | | | | | |
| 3 | PTT | To Radio PTT Input | | | | | | | | | | | | | | | | | | | | | | | | | | | |
| 4 | GND | Signal Ground | | | | | | | | | | | | | | | | | | | | | | | | | | | |
| 5 | Receive Audio | From Radio Audio (Speaker) Output | | | | | | | | | | | | | | | | | | | | | | | | | | | |
| 6 | GND | Signal Ground | | | | | | | | | | | | | | | | | | | | | | | | | | | |
| 7 | Hookswitch | Out to Radio | | | | | | | | | | | | | | | | | | | | | | | | | | | |
| 8 | COR | In from Radio | | | | | | | | | | | | | | | | | | | | | | | | | | | |

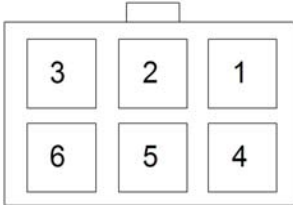
| NAME | PINOUT | NOTES | | | | | | | | | | | | | | | | | | | | | | | | | | | | | | | | | | | | | | | | | | |
|---|---|---|--------|------|---|---------|------------------|---|-----|---------------|---|-----|---------------------|---|-------------|----------------|---|-----------|-------------------------|---|---------|----------------------|---|----------|-----------------------------------|---|-----|-------------------|---|-----|---------------|----|----------|----------------|----|----------|-----------------|----|-------|-------------------|----|-----|---------------|---|
| <p>EXPANSION</p> <p>13 Pin DIN Connector on Rear Panel</p> |  <table border="1" data-bbox="951 310 1476 695"> <thead> <tr> <th>Pin</th> <th>Signal</th> <th>Note</th> </tr> </thead> <tbody> <tr> <td>1</td> <td>MIC_MIX</td> <td>Microphone Mixer</td> </tr> <tr> <td>2</td> <td>GND</td> <td>Signal Ground</td> </tr> <tr> <td>3</td> <td>PTT</td> <td>Low = True (In/Out)</td> </tr> <tr> <td>4</td> <td>SLAVE_MIXER</td> <td>Input Low=True</td> </tr> <tr> <td>5</td> <td>UNSEL_MIX</td> <td>Unselected Radios Mixer</td> </tr> <tr> <td>6</td> <td>SEL_MIX</td> <td>Selected Radio Mixer</td> </tr> <tr> <td>7</td> <td>EXT_MUTE</td> <td>Output; External Mute Logic Level</td> </tr> <tr> <td>8</td> <td>PAD</td> <td>Spare/Factory Use</td> </tr> <tr> <td>9</td> <td>GND</td> <td>Signal Ground</td> </tr> <tr> <td>10</td> <td>RX_RS232</td> <td>Serial Data In</td> </tr> <tr> <td>11</td> <td>TX_RS232</td> <td>Serial Data Out</td> </tr> <tr> <td>12</td> <td>SLAVE</td> <td>Input; Low = True</td> </tr> <tr> <td>13</td> <td>GND</td> <td>Signal Ground</td> </tr> </tbody> </table> | Pin | Signal | Note | 1 | MIC_MIX | Microphone Mixer | 2 | GND | Signal Ground | 3 | PTT | Low = True (In/Out) | 4 | SLAVE_MIXER | Input Low=True | 5 | UNSEL_MIX | Unselected Radios Mixer | 6 | SEL_MIX | Selected Radio Mixer | 7 | EXT_MUTE | Output; External Mute Logic Level | 8 | PAD | Spare/Factory Use | 9 | GND | Signal Ground | 10 | RX_RS232 | Serial Data In | 11 | TX_RS232 | Serial Data Out | 12 | SLAVE | Input; Low = True | 13 | GND | Signal Ground | <p>Connects to the Main C250 using the NCS-C250EXP Expansion Cable. The end of the cable with the yellow indicator connects to the C251 Expansion Unit.</p> |
| Pin | Signal | Note | | | | | | | | | | | | | | | | | | | | | | | | | | | | | | | | | | | | | | | | | | |
| 1 | MIC_MIX | Microphone Mixer | | | | | | | | | | | | | | | | | | | | | | | | | | | | | | | | | | | | | | | | | | |
| 2 | GND | Signal Ground | | | | | | | | | | | | | | | | | | | | | | | | | | | | | | | | | | | | | | | | | | |
| 3 | PTT | Low = True (In/Out) | | | | | | | | | | | | | | | | | | | | | | | | | | | | | | | | | | | | | | | | | | |
| 4 | SLAVE_MIXER | Input Low=True | | | | | | | | | | | | | | | | | | | | | | | | | | | | | | | | | | | | | | | | | | |
| 5 | UNSEL_MIX | Unselected Radios Mixer | | | | | | | | | | | | | | | | | | | | | | | | | | | | | | | | | | | | | | | | | | |
| 6 | SEL_MIX | Selected Radio Mixer | | | | | | | | | | | | | | | | | | | | | | | | | | | | | | | | | | | | | | | | | | |
| 7 | EXT_MUTE | Output; External Mute Logic Level | | | | | | | | | | | | | | | | | | | | | | | | | | | | | | | | | | | | | | | | | | |
| 8 | PAD | Spare/Factory Use | | | | | | | | | | | | | | | | | | | | | | | | | | | | | | | | | | | | | | | | | | |
| 9 | GND | Signal Ground | | | | | | | | | | | | | | | | | | | | | | | | | | | | | | | | | | | | | | | | | | |
| 10 | RX_RS232 | Serial Data In | | | | | | | | | | | | | | | | | | | | | | | | | | | | | | | | | | | | | | | | | | |
| 11 | TX_RS232 | Serial Data Out | | | | | | | | | | | | | | | | | | | | | | | | | | | | | | | | | | | | | | | | | | |
| 12 | SLAVE | Input; Low = True | | | | | | | | | | | | | | | | | | | | | | | | | | | | | | | | | | | | | | | | | | |
| 13 | GND | Signal Ground | | | | | | | | | | | | | | | | | | | | | | | | | | | | | | | | | | | | | | | | | | |
| <p>EXT MUTE</p> <p>RCA Phono Jack on Rear Panel</p> | <p>Center Pin - Signal Shell - Ground</p> <p>This is an open drain output that goes low when PTT is keyed, and, optionally, when any Busy Light comes on (See Section 11.2.5.3 of the C250 Manual)</p> <p>Maximum Switching Capacity: 100V, 1.5A</p> | <p>This output can be used to mute external equipment such as automobile radios or can be used to turn on external equipment such as "On-the-Air" lights.</p> | | | | | | | | | | | | | | | | | | | | | | | | | | | | | | | | | | | | | | | | | | |
| <p>SPEAKERS</p> |  <p>REAR PANEL JACK</p> | <p>DO NOT USE</p> | | | | | | | | | | | | | | | | | | | | | | | | | | | | | | | | | | | | | | | | | | |

8.0 Connecting the C251 to the C250A.

The C251 connects to the C250A using a NCS-C250EXP Expansion Cable connected to the Expansion connections on the two units. The end of the cable with the Yellow indicator connects to the Expansion Unit.

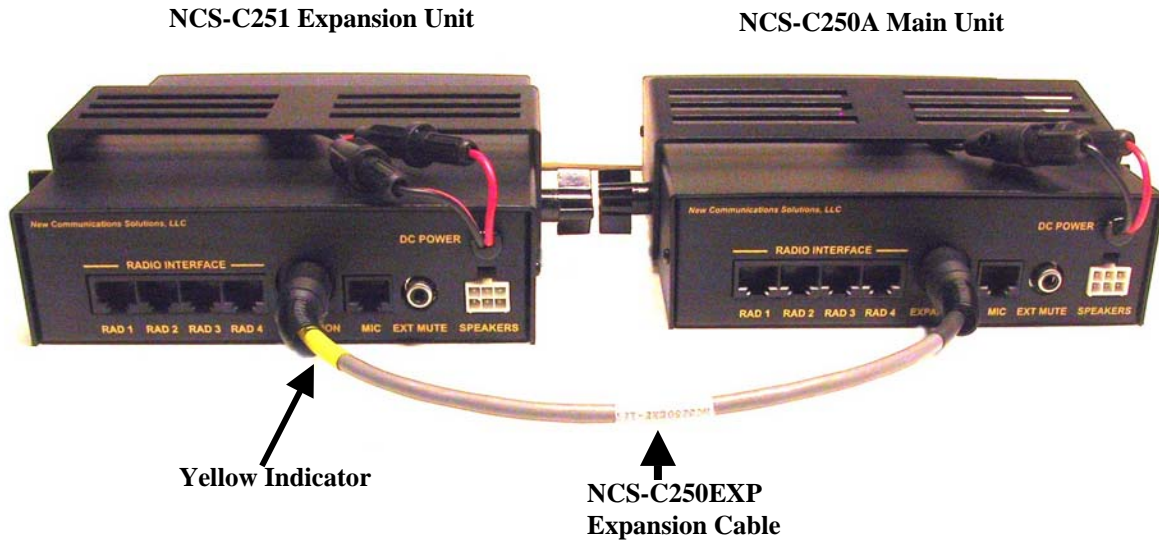

9.0 Radio Interface Cables

A Radio Interface Cable is required for each radio interfaced to the C251. This cable contains mic audio, receive audio and PTT signals. It can be fabricated from the documentation supplied in the instruction manual or obtained from NCS. The cable consists of an RJ-45, 8 pin modular connector on one end for mating to the C251 and a radio interface connector on the other end. Un-terminated cables are also available that require the customer to attach the radio interface connector.

There are two general cable configurations. The first is for radios that have the receive audio available on the microphone connector or accessory connector and the second is for radios with a separate mic connector and speaker jack. The two configurations are shown below.

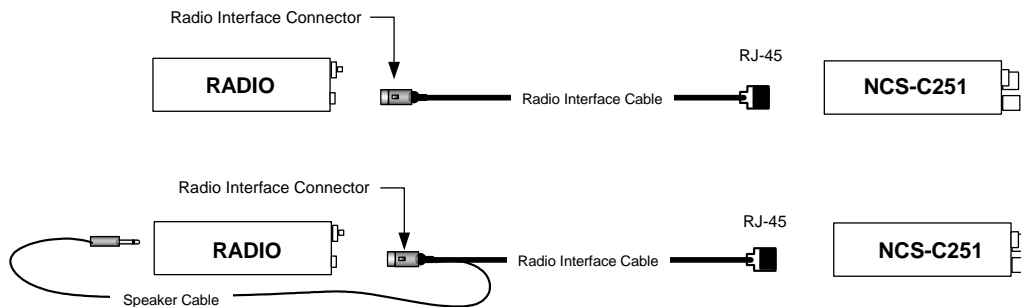

Most commercial radios have an accessory connector that usually has mic audio, receive audio and PTT connections available and usually is the preferred interface to the NCS-C251.

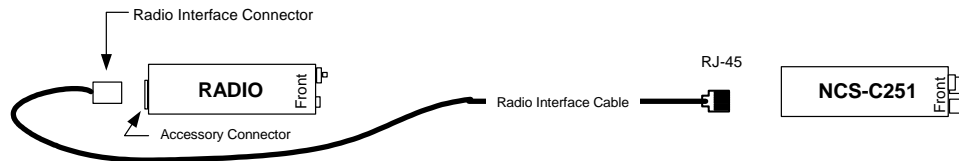

Specifying Radio Interface Cables

NCS can supply Radio Cables for most any radios. Standard cable length is six feet, however, custom lengths are available. Since there are numerous connector types for interfacing to various commercial and amateur radio transceivers, the radio model and connector type should be specified at the time of purchase. A document describing Cable Specification and Ordering is available on our website at

<http://www.ncsradio.com/documents/NCS-C250Cables.pdf>

10.0 Adjustments

10.1 Transmit Audio

Note: Transmit Adjustments can be made from inside or on the bottom of the C251. The diagrams below show the adjustment locations. NOTE: RAD1 - RAD4 on the rear and bottom of the C251 Expansion Unit correspond to RAD5-RAD8 respectively on the front panel.

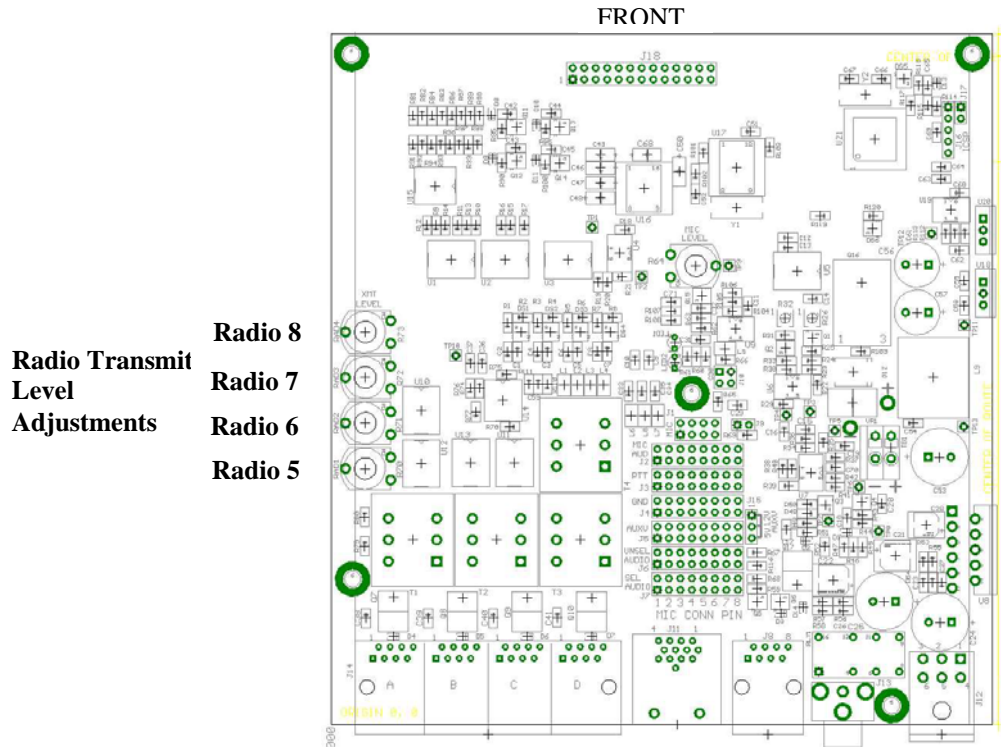

Adjustments Inside the C251

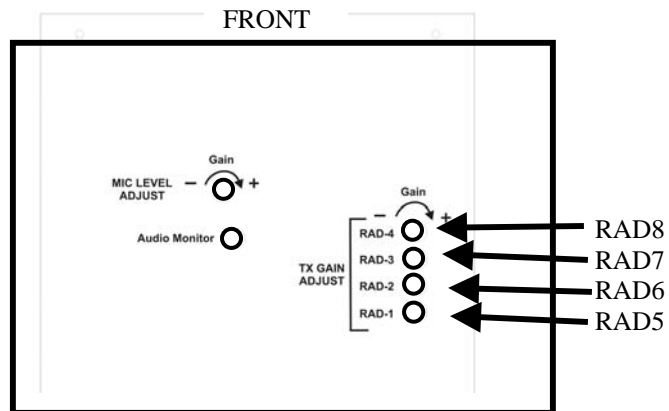

Transmit Adjustments on Bottom of C251

Transmit Audio Adjustment Procedure

- i. Adjust each transmitter for proper operation using the microphone normally used with that radio.
- ii. Connect Radio Cables between the unit and each radio.
- iii. Preset all Radio level controls to midrange (clockwise from inside, counterclockwise from the bottom, of the C251).
- iv. Select each radio in turn, press the Mic PTT, and adjust the respective output level control for proper transmitter operation.

10.2 Receive Audio

If not using the COR Option, adjust the volume control on each radio so that the Busy light on the C251 associated with that radio lights with the lowest level normal received audio. If using COR, adjust the receiver audio output in the range of 200-300mVp-p.

10.3 User Programmable Functions

The NCS-C251 has four user programmable functions. These functions are the same as those on the NCS C250A Main Unit and are turned on or off by the attached C250 Main Unit so no user programming of the C251 Expansion Unit is possible.

This completes setup and adjustment of the C251.

11.0 Operating the C251

11.1 Activating the Units

With the C251 Expansion Unit connected to the C250A Main Unit using the expansion cable, turn on the two units. It doesn't matter which unit is turned on first.

The DATA indicator on the C251 will flash slowly while the C251 is trying to connect to the C250A. Once the two units are connected, the DATA light will flash faster while the C250A sends all saved setup data to the C251. During this initial power-up sequence, all three yellow MUTE indicators on the C250A will illuminate and the AUTOMUTE indicator will blink.

After the power-up initialization, each button press on either unit will cause the DATA light to flash as the button press is shared between the two units.

11.2 Mode and Selected Radio Memory

The current Mode and the Radio Selections for all modes are automatically saved in NCS-C250A Main Unit memory so the C251 will be automatically set to the saved Mode and Radio Selection when powered off and back on.

11.3 Operating the C251

Mode setting is controlled by the NCS-C250A Main Unit. The C251 Expansion Unit will follow whatever mode the C250A is in. The front panel buttons on the C251 are used to select Radios 5 through 8.

11.4 Additional Functions

11.4.1 Watchdog Timers

Each Radio's PTT incorporates a Watchdog Timer that disables a Radio's PTT after 3 minutes of continuous transmission. To reset the Watchdog Timer and resume transmission, PTT must be released briefly. In RPT Mode, the received signal being retransmitted must stop briefly. The Watchdog Timer also resets automatically after 30 seconds even if PTT is still keyed or the received signal has not stopped. This is helpful in the event of a radio problem or other malfunction.

11.4.2 Front Panel Dimmer

The brightness of the front panel indicator LEDs is controlled by a photocell located in the front panel. This provides indicators that are not too bright in a dark environment but can still be seen in a bright environment.

12.0 COR/Hookswitch Option Board

The NCS-C250A and C251 are both available with the following features provided by the Factory Installed Option Board:

- COR (Carrier Operated Relay)

This option causes the Busy Lights and the Repeater function to be controlled by digital Busy signals from the radios. The sense of the busy signals from the radios is selectable either "High = Busy" or "Low = Busy".

When the COR Option is installed, VOX operation of the Busy Lights and Repeater Function is disabled.

- Hookswitch

This option allows a Hookswitch or microphone "hang-up" signal to be sent from the microphone through the C250A/C251 to the radios. In operation, the Hookswitch line of all Unselected radios is pulled "low". When a radio is selected, that radio's Hookswitch line is released unless the microphone connected to the C250A is hung up on a grounded hook. In this case the Hookswitch line for the Selected Radio is pulled "low".

One example of use of this feature is to activate radios' scan functions. In this application, all radios scan continuously. When the mic is lifted off its grounded hook, the Selected radio stops scanning. Scanning on the Selected radio resumes when the mic is placed back on its grounded hook.

COR Option

The COR Option uses a logic level input from the radios to illuminate the Busy lights and to operate the Repeater function. The Busy signals from the radios are on Pin 8 of the modular Radio connectors. Signal levels from the radios are:

Low: < 1.0 VDC
High: > 1.5 VDC

The sense of the Radios' Busy signals can be individually selected using the jumper block shown below. Absence of a jumper means that a "Low" signal indicates "Busy". The presence of a shunt on the jumper block means that a "High" signal indicates "Busy".

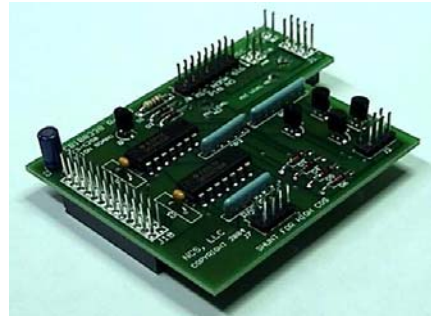
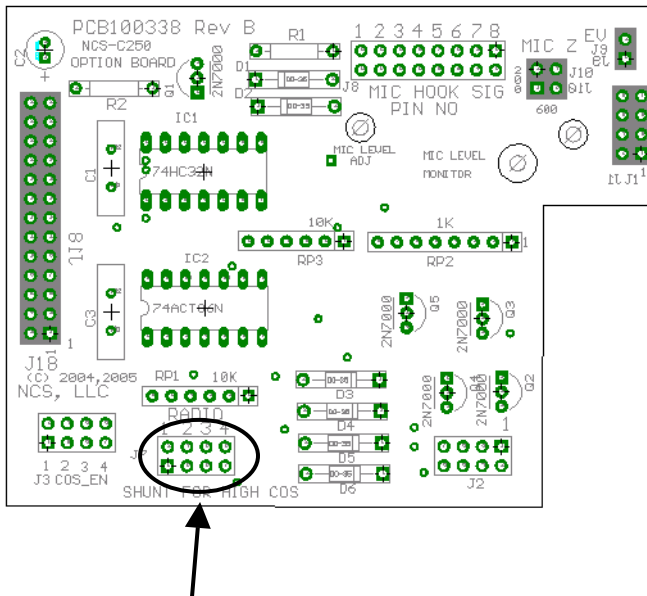

**Add Jumper for "High" Busy signal.
Do Not Add Jumper for "Low" Busy signal.**

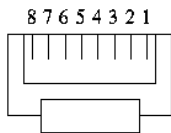

*Figure 1:
End view of RJ45 Plug*

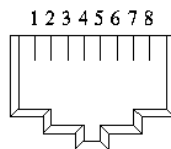

*Figure 2:
Looking into an RJ45 Jack*

RAD5-RAD8 Modular Radio Connector. Pin 8 is the COR Signal Line.

NOTE: With the COR Option installed, VOX operation of the Busy Lights and Repeater Function is disabled. Receive input levels should be set using audio voltage measurements to 200mVp-p - 300mVp-p for each radio.

12.1 Hookswitch Option

The Hookswitch Option uses an input line from the Mic connectors to activate the Hookswitch function. The Hookswitch signal from the microphone can be programmed to be on any of the 8 Mic connector pins. The state of the signal is determined by the resistance between the Hookswitch line and ground as follows:

On-Hook: < 1000 Ohms
Off-Hook: > 5000 Ohms

The Hookswitch signals to the radios are on Pin 7 of the modular Radio connectors. These signal levels are:

On Resistance: < 10 Ohms
Off Resistance: > 1 Megohm

Maximum Load Imposed by the Radio:

Off Voltage: < 60 V
On Current: < 200mA

Add Jumper to Select Microphone Pin Used for Hookswitch.

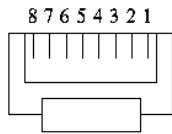
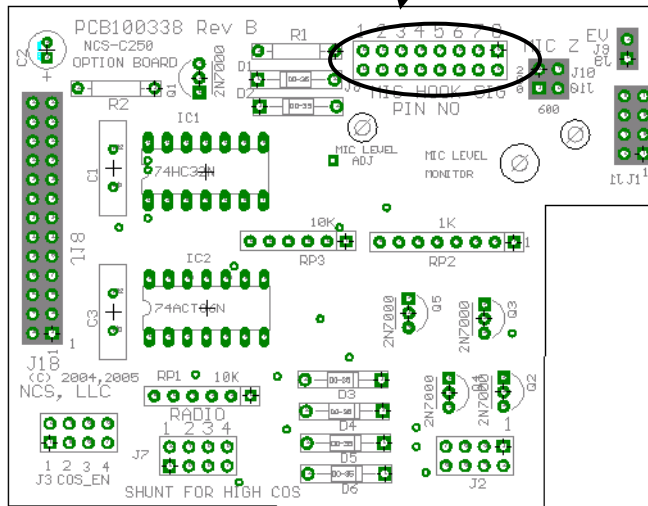

Figure 1:
End view of RJ45 Plug

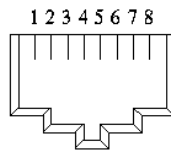
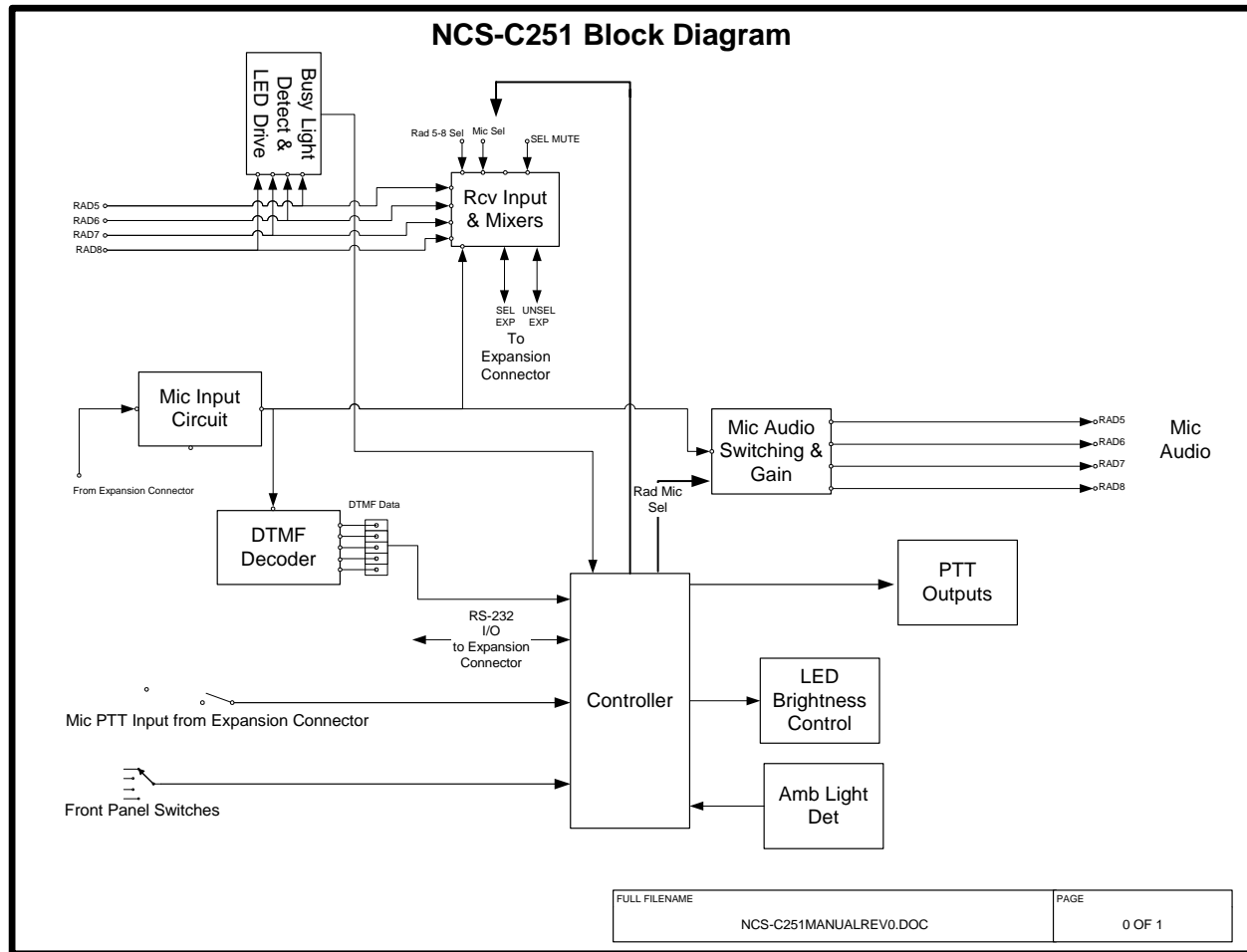

Figure 2:
Looking into an RJ45 Jack

RAD5-RAD8 Modular Radio Connector. Pin 7 is the Hookswitch Signal Line.

13.0 Block Diagram



14.0 Troubleshooting

The C251 was designed with care and uses high quality components and construction. You should not experience any operating difficulties when you follow the setup and use instructions in this manual. If you do experience problems, here is some information that may help you resolve any difficulties.

14.1 Hum

Magnetically induced hum can be caused to any modern piece of audio equipment by too close proximity to unshielded power transformers or other equipment that radiates strong AC magnetic fields. You can tell if you have this type of hum by rotating the C251 left/right, up/down and moving its position. If the hum increases and decreases, then you are experiencing magnetic coupling from an unshielded power transformer or other equipment. The C251 should be several inches away from equipment that radiates AC magnetic fields.

Another source of hum can be a ground loop. This is a situation when pieces of audio equipment that are connected together do not have their grounds well connected. This results in a voltage difference between the equipment grounds and can be a safety hazard as well as introducing electrical problems. The solution to this problem is to tie all your equipment grounds (usually case or chassis) together with a low impedance RF connection. The best choice for connecting material is a wide braid or copper strap.

14.2 Noise

Excessive noise can be caused by many factors. The C251 uses state-of-the-art low noise amplifier ICs. Nevertheless, even these components can add a bit of noise or "hiss" to an audio signal if not adjusted properly. If you seem to have excessive "hiss" type noise, review the setup and level adjustments you've made to the C251. In some cases, increasing the radio's own mic gain and decreasing the levels from the C251 may improve the noise level.

Excessive noise can also be caused by ground loops. See the previous "hum" discussion for information on eliminating ground loops.

14.3 Distortion

Distorted audio can be caused by one of two situations. The first and most common is improper adjustment of audio levels. Be sure you've adjusted the Radio and C251 level controls as recommended in this manual and that your radio's mic gain control is properly adjusted. Setting the Volume Controls at too high a level can also cause distortion.

RF at the operating position can also cause distorted audio. To determine whether this is the problem, connect your transmitter to a dummy load. If the distortion disappears, then you have RF entering the interface cables. To eliminate RF problems, first make sure you have set up the jumpers and radio cables correctly. Then check that you have a good ground between all pieces of equipment and that your RF ground is low impedance.

15.0 Contacting NCS

NCS wants you to experience trouble free operation of our equipment. If you have any questions, comments or need technical help, please use the following resources:

1. Go to the web site, www.ncsradio.com.
Here you will find the latest instruction manuals, any factory developed modifications and Frequently Asked Questions. Schematics for all NCS products may be found at www.ncsradio.com/schematics .
2. Email us at support@ncsradio.com
Be sure to include all pertinent information, e.g. make and model of radios, how they're connected to the C250, detailed description of any problems, antenna and grounding configurations, etc.
3. Telephone us toll-free at 888-883-5788.
Be near your equipment and have the manuals for your radios available. We will do our best to help you using our technical expertise.

16.0 C251 Specifications

General Specifications

| | |
|-------------------------|---|
| Dimensions | 1.8"H x 6.4"W x 7.1"D 4.6cm x 16.3cm x 18.0cm |
| Weight | 2.0 lb (0.91kg) |
| Temp Range | 0° to +50° C |
| Memory Protection | Radio Selection Switches preserved in non-volatile memory |
| Power Requirements | 9 to 16 VDC @ 2A typical |
| Automatic Mute Function | Mutes external equipment when Mic is keyed or when received signal is present (User selectable) |

Front Panel

| | |
|--------------------------|--|
| Power On/Off | Pushbutton Switch with Red LED Indicator |
| Radio Select (RAD5-RAD8) | Momentary Pushbutton Switch with Green LED "Busy" Indicator and Red LED "Selected" Indicator |
| DATA | Yellow Indicator blinks when communicating to the Main Unit |

COR Option

| | |
|-----------------------|---|
| Radio Connector Pin # | 8 |
| Signal Levels | COR Logic Input from Radio: Low: < 1.0 VDC High: > 1.5 VDC |
| COS Sense | Selectable Low or High |

Rear Panel Connections

| | |
|---|--|
| Radio Interface Connectors (1-4) RAD5-RAD8 | RJ-45 Modular Jack |
| Expansion | 13 pin DIN Jack |
| Microphone | DO NOT USE |
| External Mute | RCA Phono Jack |
| Speakers | DO NOT USE |
| DC Power | Six inch dual-fused pigtail terminated in an Anderson PowerPole PP-15 connector. |

Accessory Kit

| | |
|---------------------------|--|
| Mounting Bracket | NCS-MTG501 |
| Mounting Bracket Hardware | Qty 2 knobs with 10-32 Threaded Studs |
| Spare Fuses | Qty 2 - 3A |
| Power Cable | 10 foot, 18 AWG wire terminated with mating connector |
| Rubber Feet | Qty 4 Self Adhesive |
| Power Cable Clamp | Used to keep Power Cable from separating from Power Pigtail in Mobile use. |

Hookswitch Option

| | |
|-----------------------|--|
| Radio Connector Pin # | 7 |
| Signal Levels | Hookswitch Input Resistance to Ground: On-Hook: < 1K Ohms Off-Hook: > 5K Ohms Output Switching Resistance to Ground: On: < 10 Ohms Off: > 1 Mohm Max Load Imposed by Radio: Off Voltage: < 60 V On Current: < 200mA |

New Communications Solutions, LLC
Limited Product Warranty

All products manufactured by New Communications Solutions, LLC (hereafter referred to as NCS) and purchased from an authorized dealer or purchased directly from NCS will be warranted to be free from defects in material and workmanship for a period of one (1) year from the date of purchase.

NCS' liability under this warranty and the Customer's exclusive remedy is limited to repairing, servicing or adjusting, and/or replacing the defective product returned to NCS within the warranty period. Whether the defective product is repaired or replaced will be at the sole discretion of NCS. The warranty will be voided for products that have been abused, misused, or subjected to abnormal operating conditions as determined by NCS. Further, products damaged by lightning, power surges or force majeure events are not covered under this warranty.

If, in the Customer's estimation the product appears to be defective and is within the warranty period NCS should be notified as to the nature of the defect. If the product appears to be covered by the terms of the warranty, NCS will promptly communicate a return authorization number and shipping instructions to the Customer. When returning a product for repair/replacement under warranty the proof of purchase or a copy thereof must be returned with the defective product. NCS at its discretion may deny warranty in the absence of proof of purchase. Acceptable proof of purchase include bill of sale, cancelled check or credit card receipt. Evidence of alteration of the proof of purchase document shall be reason to immediately void the terms of the warranty.

For those products returned that prove to be defective and covered under the warranty, the Customer will bear the cost of shipment for the return of the product to NCS. Collect shipments will not be accepted. NCS will bear the cost of shipment for return of the product to the Customer after repair/replacement. Mode of shipment for return to the Customer will be determined by NCS. Should examination reveal that the product is not defective, NCS will notify the Customer and request return shipping instructions and NCS will be due all shipping expenses. In the event that the examination reveals that the product is defective, but for any reason is excluded from this warranty, NCS will prepare a quotation of the cost to repair, and will communicate same to the Customer. In the latter event, NCS will be due all shipping charges incurred for return of the product to the Customer.

The Customer may attempt to repair a defective product under warranty provided authorization to do so is received from NCS Technical Support. NCS will supply replacement parts free of charge for authorized Customer repairs provided that the defective part along with the proof of purchase is submitted to NCS. NCS will pay postage and handling for replacement parts provided the above terms are met. The product warranty under these circumstances will remain in force for the life of the warranty.

EXCEPT FOR THE EXPRESS WARRANTIES STATED IN THIS WARRANTY, WHICH ARE EXCLUSIVE, NCS DISCLAIMS ALL WARRANTIES ON PRODUCTS SOLD HEREUNDER, INCLUDING ALL IMPLIED WARRANTIES OF MERCHANTABILITY AND FITNESS FOR A PARTICULAR PURPOSE. UNDER NO CIRCUMSTANCE IS NCS LIABLE FOR CONSEQUENTIAL DAMAGES TO PERSON OR PROPERTY AS A RESULT OF THE USE OF ANY NCS PRODUCTS.

The Customer may have additional rights beyond those specifically outlined in this document based on individual state laws.